

SCREW SEGMENT, LH or RH

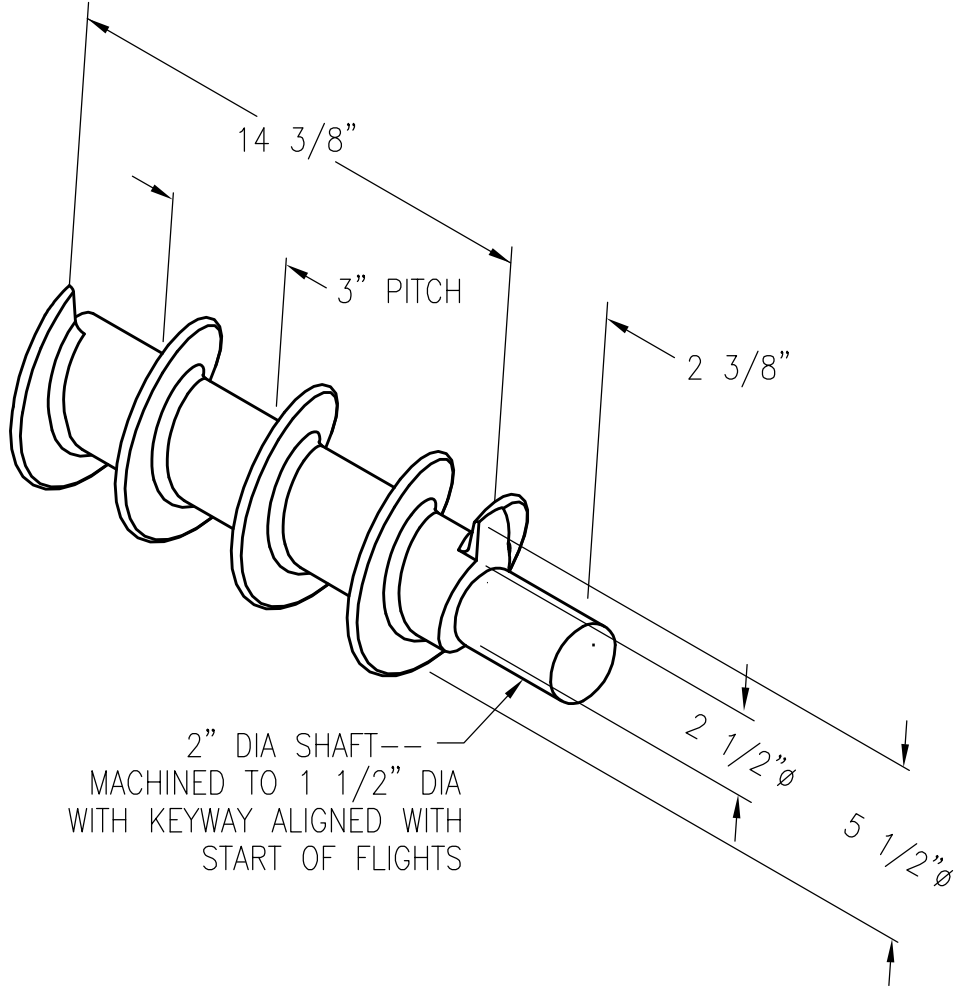

2" DIA SHAFT---
MACHINED TO 1 1/2" DIA
WITH KEYWAY ALIGNED WITH
START OF FLIGHTS

WELD TO END OF CC-3018 TO
MAKE VARIOUS LENGTHS AS REQ'D

PATTERN NUMBER: CC-3021-R or -L
DRAWING NUMBER: CA-2352-C

F045

WEIGHT: 24#